

POP CAN CAR CHALLENGE

Name: _____

H.R. _____

Using your knowledge of structures, speed, weight, gravity and friction, your challenge is to build a car which will travel the longest distance!

Criteria - Design, create and build a Pop Can Car that will speed down a 1m high, 2.5m long and 0.23m wide ramp. The Pop Can Car will compete against other entries in the race. The dimensions of the vehicle cannot be less than 80mm wide X 200mm long X 60mm high and the width cannot exceed 220mm. The side view of the car should be made out of hardboard and cut to resemble a car's exterior. Be creative with design and be sure to decorate your car.

Tools and Materials

1 - Square stock wooden sticks (length 61cm)	Scrap wood		
1 - 300mm x 8mm wooden axles	Glue Gun and glue sticks		
1 - Straw (spacers)	Wood Glue		
2 - 25cm x 10cm hardboard (for car sides)	Scroll Saw		
4, 6 or 8 pop cans (bring your own)	Drill Press		
Hack Saw	Razor Saw	Spindle Sander	
Coping Saw	Sand Paper	Mitre Box	Jointers
Clamps	Back Saw	Paint	Brushes

Tasks - You will plan and construct a Pop Can Car evaluated on the following elements:

1. Students will work individually.
2. Complete an orthographic drawing (front, right and top sides) in a scale of 1:1 (life sized) of the car you wish to build. Use a pencil, ruler and graph paper. Remember all measurements are in millimetres. Complete "Calculating Materials". Measure out all the pieces and make a list of all your lengths to show the total amount of wood you'll be using. Show me your completed drawings and calculations.
3. The Pop Can Car must meet the criteria stated above.
4. Use **gussets** for reinforcing.

Due date will be at the beginning of the period on _____.

Safety First!

- Remember to follow all D&T Safety Rules and Regulations.
- Use cutting tools safely.
- Use hot glue guns safely.

Helpful Hints!

WHEEL ASSEMBLY

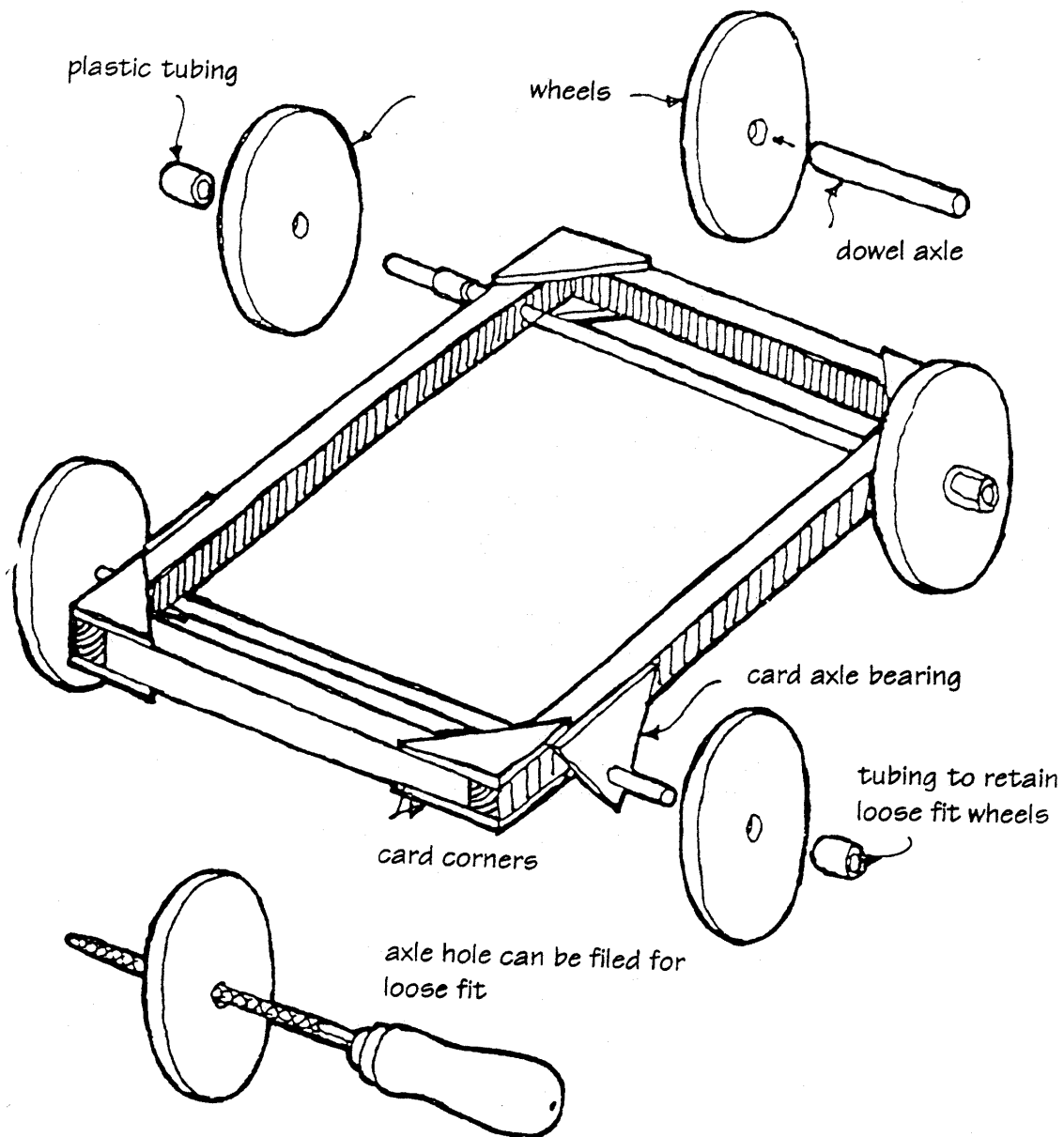

EVALUATION OF DRAWINGS - 20 marks

All views will be drawn to a scale of 1:1 (life sized). You must use a pencil and ruler for all parts of the drawing, including the dimension arrows. All measurements are in millimetres. Label each drawing and be sure they are neat.

Front View - 5 marks

0 1 2 3 4 5

Top View - 5 marks

0 1 2 3 4 5

Side View -5 marks

0 1 2 3 4 5

Calculating Materials - 5 marks

Show all your work for "Calculating Materials". This proves that your design uses no more wood than the maximum amount allowed. Measure out all the pieces and make a list of all your lengths to show the total amount of wood you'll be using.

0 1 2 3 4 5

SUB-TOTAL /20

Evaluation of Construction Process

The prototype is complete.

0 1 2 3 4 5 6 7 8 9 10

The dimensions meet the criteria.

0 1 2 3 4 5 6 7 8 9 10

The prototype resembles a car's exterior, with smooth edges and precise cuts.

0 1 2 3 4 5 6 7 8 9 10

Axles are centered in the wheels.

0 1 2 3 4 5 6 7 8 9 10

The prototype has clean joints and looks presentable.

0 1 2 3 4 5

The prototype uses the "JINKS method to fasten the mechanical joints.

0 1 2 3 4 5

The prototype has been decorated originally and neatly.

0 1 2 3 4 5 6 7 8 9 10

You worked safely and tidied up your work area.

0 1 2 3 4 5

The prototype traveled the distance of _____. (One point per metre)

0 1 2 3 4 5 6 7 8 9 10

SUB-TOTAL /70

TOTAL _____

90

LEVEL _____

Useful Websites:

<http://www.pbs.org/teachers/connect/resources/6143/preview/>

<http://www.sciencekids.co.nz/gamesactivities/friction.html>

<http://www.sciencekids.co.nz/gamesactivities/forcesinaction.html>